

FOR OFF ROAD/RACE USE ONLY!



Driven TT Rearsets for 11-15 Kawasaki ZX-10R

Part#: DRP-715

INSTALLATION INSTRUCTIONS

Removal

Shifter Side

1. Remove OEM shift rod from bike.
2. Remove frame plate from bike.

Brake Side

1. Remove 2 m8 bolts holding heal guard.
2. Remove master cylinder plunger pin and retain split pin.
3. Remove 2 m8 bolts and remove frame bracket.
4. Remove rear brake switch and disconnect it from bike.

THE USE OF BLUE LOCTITE IS REQUIRED ON ALL MOUNTING HARDWARE!

Installation

Shifter Side

1. Install foot peg in frame bracket.
2. Install shift rod.
3. Install frame bracket onto bike.
4. Adjust shift pedal with shift rod and tighten both safety nuts.

Brake Side

1. Install foot peg in frame bracket.
2. Connect master cylinder plunger to brake lever using OEM cotter and pin.
3. Install frame bracket to bike.
4. Install master cylinder using 2 m8 bolts supplied.
5. Use blue Loctite on all bolts and torque all to required setting.
6. Make sure nothing interferes with proper operation of motorcycle.

TOOLS REQUIRED

- 8mm Open End Wrench
- 5mm Hex Key
- 6mm Hex Key
- 8mm Hex Key
- Needle Nose Pliers
- Screw Driver
- Blue Loctite
- Impact Gun

Make final adjustments as necessary and re-check all hardware after the first 500 miles of use.

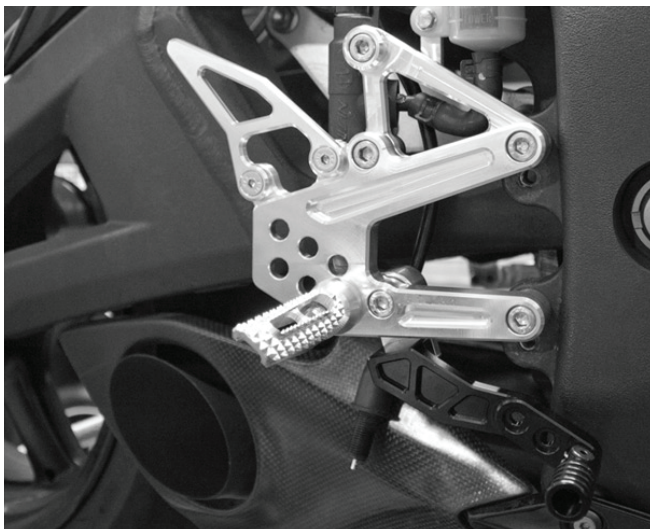

(Fig 1.)

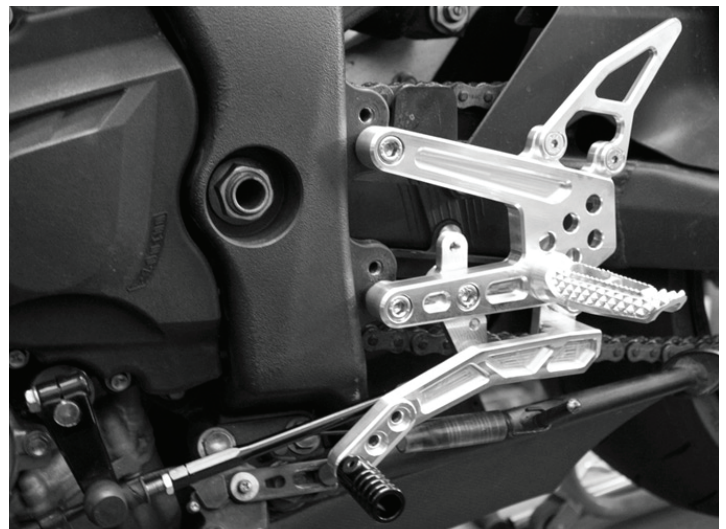

(Fig 2.)

THIS PRODUCT IS INTENDED TO BE INSTALLED BY A CERTIFIED TECHNICIAN*

FOR OFF ROAD/RACE USE ONLY!



Driven TT Rearsets for 11-15 Kawasaki ZX-10R
Part#: DRP-715

LEFT SIDE / SHIFTER
 A00026

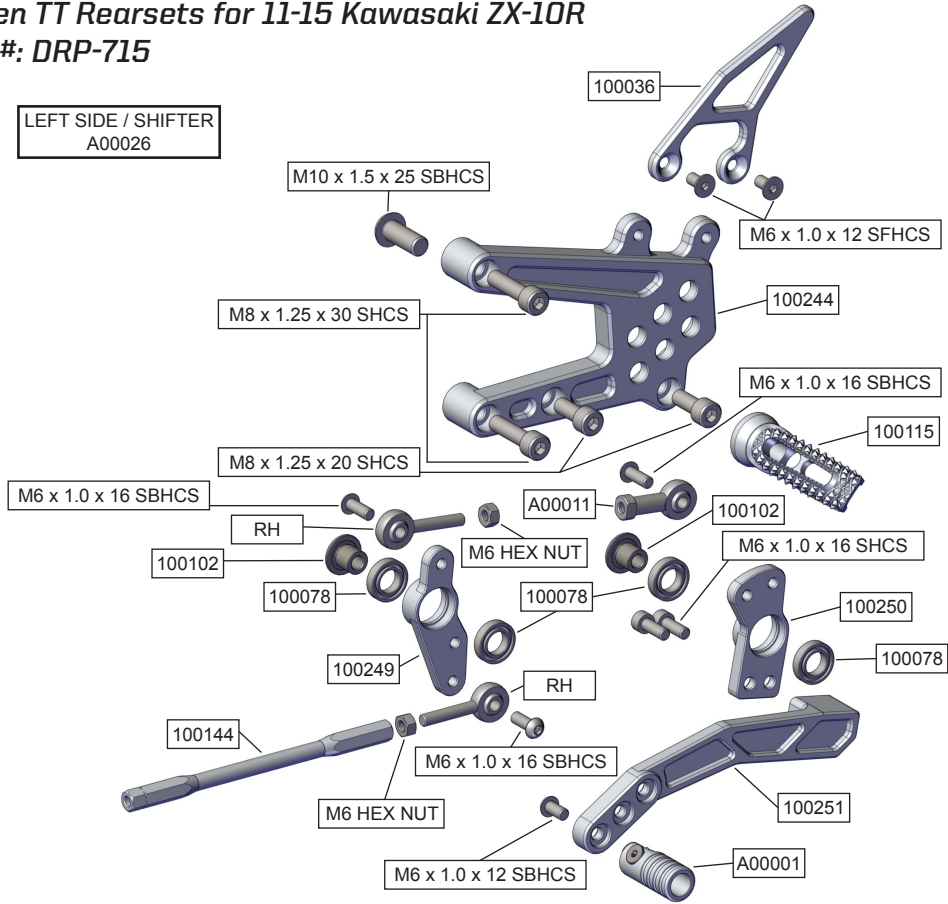

RIGHT SIDE / BRAKE
 A00027

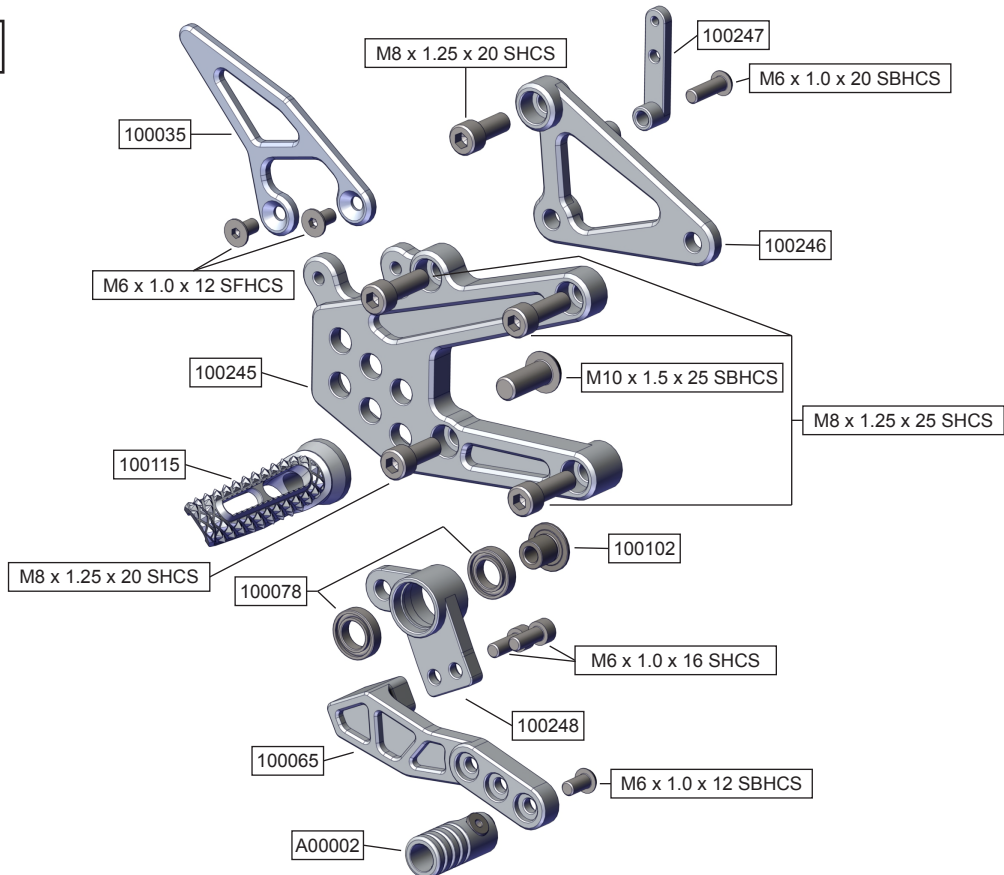

THIS PRODUCT IS INTENDED TO BE INSTALLED BY A CERTIFIED TECHNICIAN*